

12V HIGH POWER LVC DESULPHATOR

C1	10uF	1off
C2	0.0022uF	1off
C3	0.047uF	1off
C4	330uF	1off
C5	0.1uF	1off
C6	0.01uF	1off
D1, D2 & D4	1N4148	3off
D3	1N5408	1off
D5	FES16J or equivalent	1off
D6	15V Zener	1off
F1	RTC Fuse	1off
IC1	LM555N	1off
IC2	NJM5534	1off
L1	100uH	1off
L2	1000uH	1off
LED2	LED5MM	1off
Q2	IRF9520N	1off
R1	270k (RPY or RPBO)	1off
R3	100R (BrBBR)	1off
R4 & R5	330R (OOBr or OOBB)	1off
R6	1k8 (BrGyR or BGyBBR)	1off
R7a	12k 1% (BrRBRBr)	1off
R7b	270R 1% (RPBBBr)	1off
R8	10k 1% (BrBO)	1off
R9	100k 1% (BrBBOBr)	1off

2off 50k thermistors glued to D1 and Q2 + 2off additional 22k (RRO or RRBrR) to be mounted in series

PCB	1off
8pin DIL socket	2off
M4 x 12mm bolt	2off
M4 nut	4off
M4 washer	4off

Resistor Colour Codes: B – black, Br – brown, Gy – Grey, O – orange, P – purple, R – red, Y – yellow

Please note schematic shown as illustration only, actual components may vary

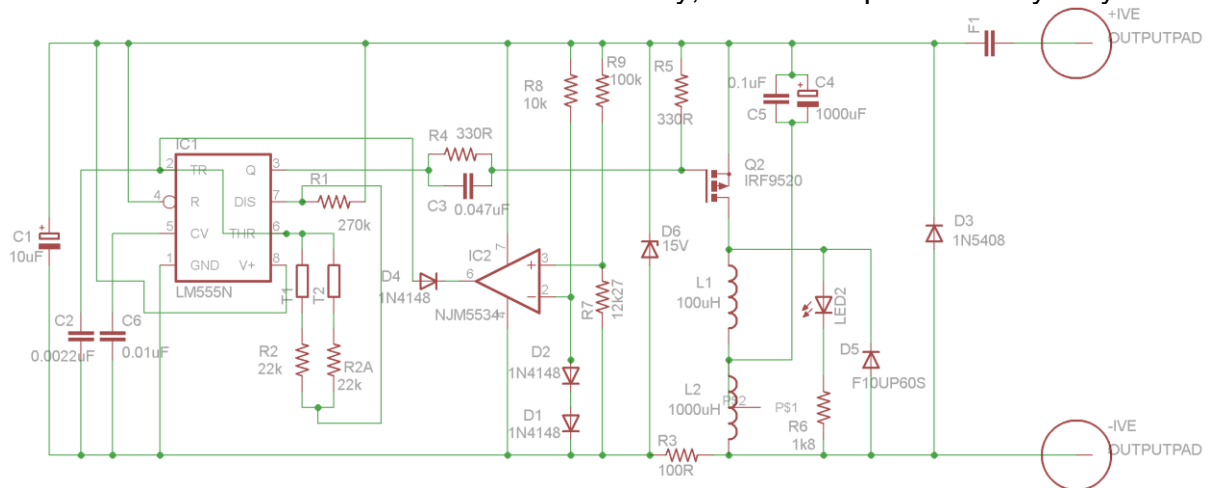

DO NOT CONNECT THE PULSER TO THE BATTERY CHARGER – CONNECT IT TO THE BATTERY & THEN CONNECT THE CHARGER. MAKE SURE THE BATTERY CHARGER IS UNPLUGGED FROM THE MAINS SUPPLY BEFORE CONNECTING/ DISCONNECTING

1. Check all components/ parts as listed above are present.
2. Carefully remove the 555 & NJM5534 chip from their DIL sockets, do not insert until after all soldering of both the socket and immediately adjacent components is complete. Please note that the 555 should be inserted with the dot (indentation) on the device nearest to C2 on the PCB and the NJM5534 with the dot nearest R4.
3. You can choose to solder the 4mm bolts to the PCB or solder your output cables direct. To solder the 4mm nuts and bolts to the PCB you will need to drill out the two 3.3mm holes marked –ve and +ve to 4mm. Then place a bolt through each hole and secure tightly with a nut. The bolts take a fair bit of heating but the solder will take eventually. As you will see from the pictures on the web site the solder mask does bubble to reflect the amount of heat being used at this point.
4. Components can then be inserted in any order, obviously excessive heat should be avoided. Note that R7 consists of both the 12k and 270R resistors in series.

Please note as of 14/09/11 we are changing some resistor values to reflect changes to the inductors. R1 has been altered from 470k to 270k. We have ordered some 270k resistors but 'pro tem' we are supply a 100k and 180k which should be inserted as shown here (note this picture is actually our standard PCB but illustrates the intent).

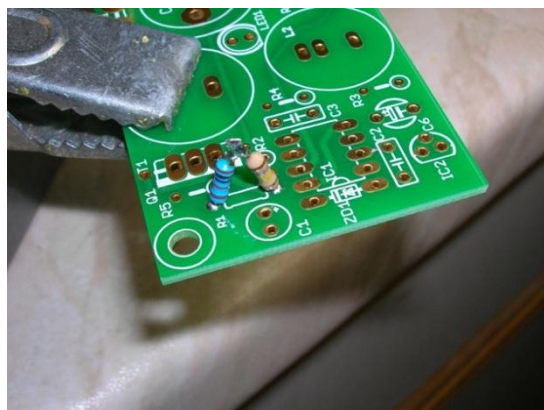

The following two photo's show how the 'new' series 22k resistors should be fitted (the actual resistors shown are 10k and also show the banded end of D3 'pointing to the +ive output terminal).



I'm assuming you are aware that the band on an electrolytic capacitor indicates the negative!! In the case of C4 the banded side should be closest to the C5 position.

Please note that the LED needs inserting the opposite way around to that shown on the PCB!

The MOSFET should be soldered in last though and should not be 'overly' handled. In my opinion they are not as sensitive to static as some might have you believe.

5. D3, the reverse polarity diode, should be mounted with the band towards the +ive output terminal.
6. The LED positive is the longer lead. The long lead should also be mounted nearest C4.
7. C5 allows the high frequency bits to pass more readily than through C4.

What will produce a greater gain would be fitting a larger C4, up to 6,800uF/ 25V has been recommended. It certainly provides a greater store of energy. If you go this route you'd be advised to fit a pot. in place of R2 to allow you to adjust the pulse if necessary i.e. the inductors or MOSFET start getting hot.

8. There is not a great deal of clearance between the output lead of D2 and the +ive terminal especially if you use the 4mm bolt option. The gap is adequate but I would suggest that you

solder the end nearest the –ive terminal first then crimp the output lead to the body of the diode with a pair of suitably sized pliers prior to soldering it.

9. The resettable fuse is the mustard coloured small disc marked R60 – this should be soldered across the points marked F1 with the leads as short as possible.
10. If you use the 4mm bolt output terminal option I would strongly suggest you solder the ring terminals to the output cables, do not just crimp. Every poor connection is losing energy. I would advise using leads of at least 10 or 12AWG for the output. These may seem OTT but they do seem to make a difference.

There is no point after this just using crocodile clips to connect to the battery. Use proper battery terminal connectors and a soldered ring terminal and do the connections up properly. To give you an idea of what you lose here on a 'high power' pulser fitted with a peak detector I was losing 20V through crocodile clips against a proper battery terminal clamp.

11. On completion check and double check that the right components are in the right place, and that there are no solder bridges.
12. Connect the negative lead from the pulser to the battery negative terminal first. Then briefly touch the positive lead to the positive terminal i.e. 1-2 seconds and note:-
 - a) low level sparks as the lead contacts the battery terminal
 - b) the LED should illuminate
 - c) you should hear a distinct circa 1k2Hz tone from the PCB.

If you get all three then connect the pulser for progressively longer periods and monitor the coils/ MOSFET and diode for excessive heat. Once you have got to a minute it is fairly safe to assume that all is well.

If you get only some or none of the above then clearly something is wrong. Re-check the components are in the right place and adequately soldered and that there are no bridges or dry joints.

This device consumes in the region of 40-60mA so will obviously drain the battery if it is not charged.

I would suggest that you connect both the device and a trickle charger to the battery undergoing recovery (having first checked that the electrolyte level is OK) and leave the pulser to do its thing.

The voltage to which the battery will charge should increase over a period of 10-14 days, a really large battery may take longer. If you do not see this improvement then it is likely that the cause of the batteries poor performance is other than sulphation or that it is already too bad and the sulphation has bridged plates internally.

I can be contacted at enquiries@courtiestown.co.uk or on 0146 483 1490. With regard to the latter option be aware I work offshore for half my life and that my wife may not be able to offer that much assistance and also that calls should be made at a civilised hour i.e. before 2100.